

Manual Section 7	Issue Date 12/01/09	Revision Date 06/15/21	Policy Number LLCP-068
	Fall Hazard Management		

Purpose

This Practice provides the minimum requirements to ensure the safety of employees performing work in elevated areas.

Scope

All LLC Companies including, Blanchard Industrial, LLC, GIS Engineering, LLC, Grand Isle Shipyard, Inc., and GWIS, Mack Steel, NuWave, Sun Industries; hereafter identified as “Company”.

References

Title 29 Code of Federal Regulation (CFR) Part 1926 Subpart M (1926.500 – 1926.503)

Definitions

Continuous Fall Protection – Protecting the worker from the possibility of a fall at all times. This includes when moving or stationary. Continuous fall protection includes guardrail systems, nets, tie off, catch platforms, etc.

Continuous Tie Off – Using safety harnesses with lanyard(s) tied-off at all times. Usually this means using two lanyards

Anchorage – A secure point of attachment for lifelines, lanyards, or deceleration devices. The anchorage shall be capable of withstanding the forces specified in this practice.

Approved – For the purpose of this practice; tested and certified by the manufacturer or any recognized national testing laboratory to possess the strength requirements specified in this section.

Full Body Harness – A configuration of connected straps used to distribute a fall arresting force over at least the thighs, shoulders, and pelvis, with provisions for attaching a lanyard, lifeline, or deceleration device.

Fall Arrest System – A full body harness and lanyard which, is attached to a horizontal or vertical lifeline which is properly secured to an anchorage(s).

Catch Platform – A platform with guardrails set up next to a fall edge to “catch” fallen employees. The platform shall be within six vertical feet of the edge with no openings an employee could fall through.

Catenary Line – see – Horizontal Lifeline below.

Competent Person – An individual Knowledgeable of fall protection equipment. This knowledge includes the manufacturer’s recommendations and instructions for proper use, inspection, and maintenance; and who is capable of identifying existing and potential fall hazards. A Competent Person has the authority to take prompt corrective action to eliminate those hazards and is knowledgeable of the rules contained in this section regarding the erection, use, inspection, and maintenance of fall protection equipment and systems.

Control Zone – The area between the warning line and the unprotected sides and edges of a building/structure floor or roof surface.

Manual Section 7	Issue Date 12/01/09	Revision Date 06/15/21	Policy Number LLCP-068
	Fall Hazard Management		

Acceleration Device – Any mechanism, such as a rope grab, rip-stitch lanyard, or automatic self-retracting lifeline, which serves to dissipate more energy during fall arrest than a standard line or strap webbing lanyard.

Drop Line – An independent lifeline secured to an upper anchorage for the purpose of attaching a lanyard or a fall protection device. This line must be at least a ¾ inch manila rope or a ½ inch nylon rope

Fall Hazard – Where the potential for an employee to fall, (i.e., to a level 6 feet or more below, 6 feet or more on the same level or into hazardous machinery or equipment).

Fall Protection Work Plan – A written document in which the employer identifies all areas on the jobsite where a fall hazard exists. The plan describes the method or methods of fall protection to be used to protect employees, and includes the procedures governing the installation, use, inspection, and removal of the fall protection methods which are selected by the employer.

Fall-Restraint System – An approved device and any necessary components that function together to restrain an employee in such a manner as to prevent that employee from falling to a lower level. When standard guardrails are selected, compliance with applicable sections governing their construction and use shall constitute approval.

Fall Distance – The actual distance between the location of an employee’s harness attachment point and location of the attachment point when it comes to a full stop.

Hardware – Snap hooks, D-rings, buckles, carabiners, adjusters, and O-rings that are used to attach the components of a fall protection system together.

Hole – A gap or void 2 inches or more in its least dimension in a floor, roof, or other walking/working surface.

Horizontal Lifeline – A rail, wire rope, or synthetic rope that is installed in a horizontal plane between two anchorage points and used for attachment of a worker’s lanyard or lifeline device while moving horizontally.

Lanyard – A flexible line of webbing, rope, or cable used to secure a harness to a lifeline or an anchorage point usually 2, 4 or 6, feet long.

Leading Edge – Means the advancing edge of a floor, roof, or form work which changes location as additional floor, roof, or form work sections are placed, formed, or constructed. Leading edges not actively under construction are considered to be “unprotected sides and edges,” and positive methods of fall arrest or fall restraint shall be required to protect exposed workers.

Lifeline – A vertical line from a fixed anchorage or between two horizontal anchorage points, independent of walking or working surfaces, to which a lanyard or device is secured. Lifeline as referred to in this text is one which is part of a fall protection system used as back-up for an elevated worker.

Manual Section 7	Issue Date 12/01/09	Revision Date 06/15/21	Policy Number LLCP-068
	Fall Hazard Management		

Locking Snap Hook – A connecting snap hook that requires two separate forces to open the gate, one to deactivate the gatekeeper and a second to depress and open the gate which automatically closes when released; used to minimize roll-out or accidental disengagement.

Low Pitched Roof – A roof having a slope equal to or less than 4 in 12.

Positioning Belt – Single or multiple strap that can be secured around the worker’s body to hold the user in a work position, for example, a lineman’s belt, a re-bar belt, or a saddle belt.

Restraint Line – A line from a fixed anchorage or between two anchorage points to which an employee is secured in such was at to prevent the worker form falling.

Roll-Out – Unintentional disengagement of a snap hook caused by the gate being depressed under torque or contact while twisting or turning.

Rope Grab – A fall arresting device that is designed to move up or down a lifeline suspended from a fixed overhead or horizontal anchorage point, or lifeline, to which the harness is attached. In the event of a fall, the rope grab locks onto the lifeline rope through compression to arrest the fall. The use of a rope grab device is restricted for fall restraint applications.

Safety Line – see Horizontal lifeline, above.

Safety Monitor System – A system of fall restraint used in conjunction with a warning line system only. A Competent Person, as defined above under Competent Person, having no additional duties, monitors the proximity of workers to the fall hazard when working between the warning line and the unprotected sides and edges, including the leading edge of a low-pitched roof or walking/working surface.

Self-Retracting Lifeline – A deceleration device containing a drum-wound line that may be slowly extracted from or retracted onto the drum under slight tension during normal employee movement and, after onset of a fall, automatically locks the drum and arrests the fall.

Shock-Absorbing Lanyard – A flexible line of webbing, cable, or rope used to secure a body belt or harness to a lifeline or anchorage point that has an integral shock absorber.

Single-Action Snap Hook – A connecting snap hook that requires a single force to open the gate, which automatically closes when released.

Snap Hook – A self-closing connecting device with a gatekeeper latch or similar arrangement that will remain closed until manually opened. This includes single-action snap hooks that open when the gatekeeper is depressed and double-action snap hooks that require a second action on a gatekeeper before the gate can be opened.

Static Line – see Horizontal Lifeline, above.

Strength Member – Any component of a fall protection system that could be subject to loading in the event of a fall.

Manual Section 7	Issue Date 12/01/09	Revision Date 06/15/21	Policy Number LLCP-068
	Fall Hazard Management		

Steep Roof – A roof t a slope greater than 4 in 12.

Unprotected Sides and Edges – Any side or edge (except at entrances to points of access) of a floor, roof, ramp, or runway where there is not wall or guardrail system as defined in this section.

Work Area – That portion of a walking/working surface where job duties are being performed.

Requirements

It is the policy and intent of the Company that employees shall be protected from fall hazards by using continuous fall protection as defined above. **Employees are to wear Company purchased/approved equipment ONLY which are approved by ANSI or must complete a MOC.**

Before starting a project, construction management shall make an initial survey of the types of fall hazards expected and develop a Plan for providing the kind and number of safeguards that shall protect employees from these fall hazards. *A fall exposure occurs when an employee's feet are six (6) feet or more above a work area.* The Plan shall meet the requirements of Title 29 Code of Federal Regulations (CFR) Part 1926 Subpart M.

All personnel will be required in the absence of other acceptable fall protection methods to wear an approved full body harness and two lanyards or SRD (self-retracting device).

The Company and our subcontractors shall make maximum use of primary fall protection systems such as scaffolds, aerial lifts, scissors lifts, etc. These systems shall be equipped with complete working/walking surfaces free of floor openings, standard guardrail systems for a safe means of access.

Personnel traveling or working in elevated areas, where a fall exposure exists, shall make use of fall protection in securing their safety lanyard at all times to a structure, lifeline or approved device capable of supporting 5,000 pounds.

Personnel working from, or traveling in, powered work platforms or personnel lifting or hoisting devices shall also properly secure their safety lanyards.

Fall protection devices subjected to shock loading imposed during a fall arrest shall be immediately removed from service.

To ensure the highest level of protection for all employees, when purchasing fall protection equipment/raw materials for use in a fall protection system, the American National Standards Institute (ANSI) and American Standard of Testing Materials (ASTM) requirements should be met.

Methods of Fall Protection

Primary Fall Protection Systems

These systems provide walking and working surfaces in elevated areas which are free from floor openings and are equipped with standard guardrail system on all sides and with closure apparatus for ladder openings or other points of access when required. These systems include, but are not limited to: scaffolds, pencil boards, aerial lifts (JLG, scissors, lifts, etc.) and other approved personnel hoisting devices.

Manual Section 7	Issue Date 12/01/09	Revision Date 06/15/21	Policy Number LLCP-068
	Fall Hazard Management		

Standard guardrail systems consist of a top rail of 2 x 4 inch lumber or equivalent material approximately forty-two inches (42) above the walking/working surfaces, a mid rail at approximately twenty-one inches (21) above said surface and a four-inch (4) tall toe board mounted at the walking/working surface. Upright support post spacing must not exceed eight feet (8) and the entire system must be capable of supporting 200 pounds of force in any direction with minimum deflection. These systems are used to guard open sides of floors, platforms and walkways in elevated areas.

Mid rails, screens, mesh, intermediate vertical members, solid panels, and equivalent structural members shall be capable of withstanding a force of 150 pounds applied in any downward or outward direction at any point along the mid rail or other member. Guardrail systems shall be surfaced to protect employees from punctures or lacerations and to prevent clothing from snagging.

The ends of the top rail and mid rail must not overhang the terminal post, except where such an overhang does not constitute a projection hazard.

Guardrail systems must be set up on all unprotected sides and edges. When holes are used for the passage of materials, the hole shall have not more than two sides with removable guardrail sections. When the hole is not in use, it must be covered or provided with guardrails along all unprotected edges. Guardrails must be used at unprotected sides or edges of ramps and runways; they must be erected on each unprotected side or edge.

Guardrails are not to be used to hoist materials or equipment to an elevated work area. Floor openings/hole covers are used to close openings and holes in floor platforms and walkways. These covers must be capable of supporting maximum potential load they may be subjected to. The cover must completely cover the opening/hole and be secured against accidental displacement. These covers must be marked "**HOLE COVER DO NOT REMOVE**", painted a highly visible color (orange).

Secondary Fall Protection Systems - Harness/Lanyard Systems

These systems must be worn and used as a backup to the Primary Fall Protection System noted above in the absence of the Primary System.

Lanyards will be a maximum of six feet (6) in length, with double locking hooks, when used for fall protection. Lanyards of lengths greater than six feet (6) shall not be used. Two lanyards, allowing for a total distance or more than six feet (6) shall not be connected together.

D-rings and snap hooks must have minimum tensile strength of 5,000 pounds. D-rings and snap hooks shall be proof tested to a minimum of 3,600 pounds without cracking, breaking, or suffering permanent deformation. Snap hooks must not allow pressure to be applied to the gate in the opening direction. **(Pelican hooks shall not be used)** D-rings shall be a minimum of 2 ¼" (inside diameter) located at the waist or chest may only be used for positioning or with rail climbing devices. Work positioning lanyards are to be attached to the D-rings at the waist belt location and be supported by an appropriate work belt. Positioning lanyards need not be shock-absorbing type and must not be used for fall protection. The positioning lanyard must always be backed up by a properly secured shock absorbing fall protection lanyard or other appropriate fall protection device such as a retractable vertical lifeline.

Manual Section 7	Issue Date 12/01/09	Revision Date 06/15/21	Policy Number LLCP-068
	Fall Hazard Management		

Subcontractors shall provide appropriate fall protection equipment to their employees. Personal Fall Arrest systems (Safety Harness & Lanyard) must be inspected prior to each use for damage and other deterioration. All fall protection equipment is to be inspected and documented on a monthly basis. Defective components must be removed from service.

Lifelines

Lifelines are points of attachment for fall protection lanyards mid must be capable of supporting at least 5,000 pounds. Lifelines may be mounted either vertically or horizontally are generally intended to provide mobility to personnel working elevated areas.

Horizontal lifelines must be made of at least 5/8" inch wire rope properly supported to withstand at least 5,000 pounds impact. Alternate materials for specific cases (i.e. use of synthetic fiber rope) must be approved by the HSE Department.

Horizontal lifelines shall be positioned so as to provide points of attachment at waist level or higher to personnel using them.

Lifelines shall not be used for any other purpose other than fall protection. Subcontractors must install and maintain their own lifelines by project safety specifications.

Vertical lifelines are used for personnel fall protection when vertical mobility is required and may be comprised of static lifeline made of synthetic fiber rope or cable equipped with an approved sliding rope grab, or they must consist of a self-retracting reel type lanyard/lifelines which are attached directly to the safety harness.

Self retracting lifelines and lanyards that automatically limit free fall distance to 2 feet or less shall be capable of sustaining a minimum tensile load of 3,000 pounds applied to the device with the lifeline or lanyard in the fully extended position.

Self retracting lifelines or lanyards that do not limit the free fall distance to 2 feet or less, rip-stitch lanyards, and tearing and deforming lanyards shall be capable of sustaining a minimum tensile load of 5,000 pounds applied to the device with the lifeline in the fully extended position.

Retractable lifeline devices shall be secured by means of shackles and wire rope chokers or synthetic slings. **ROPE** (synthetic or natural fiber) **SHALL NOT BE USED TO SECURE THESE DEVICES.**

Each retractable lifeline device shall be equipped with a rope tagline for extending the device to elevations below the point of attachment.

Static rope lifelines with rope grab systems or approved retracting; reel lifelines are required for personnel working from spider baskets/sky climbers, and two point suspension scaffolds. These types of lifelines can also be used to provide fall protection for other operations such as scaffold erection and structural steel erection where tie off points are limited and vertical mobility is required.

Sliding rope grab approved for the size rope and use are the only method for securing a safety lanyard to a vertical lifeline. Lanyards shall not be attached to lifelines by means of knots or loops.

Manual Section 7	Issue Date 12/01/09	Revision Date 06/15/21	Policy Number LLCP-068
	Fall Hazard Management		

Rope grabs shall be positioned on the lifeline at least above the shoulder of the user. Priority shall be given to lifeline placement as structures are erected.

Lifelines shall be arranged to provide adequate mobility in all areas of the structure while maintaining Continuous fall protection for personnel.

Personnel installing lifelines shall be protected from falls at all times by use of retractable lifelines or tie off to structural steel, etc.

Lifeline systems shall be inspected on a regular basis and documented. Softeners shall be used where lifelines contact sharp edges such as beam flanges.

Connector Toggles

These devices lock into structural steel bolt holes to provide an attachment point for a safety lanyard. These devices may be used by structural steel connectors and bolt up personnel during steel erection.

Concrete Form Tie-Offs

This device attaches to patented concrete forms to provide an attachment point for safety lanyards. These devices may be used when placing concrete forms at elevated areas where a fall hazard exists.

Anchor Points

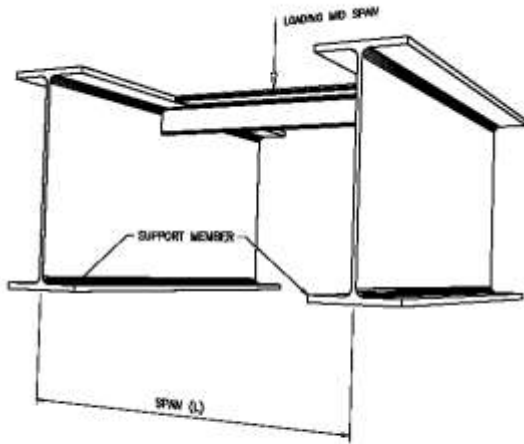

FIGURE 1
INTERCOSTAL MEMBER – HORIZONTAL
SCALE: 1-1/2" = 1'-0"

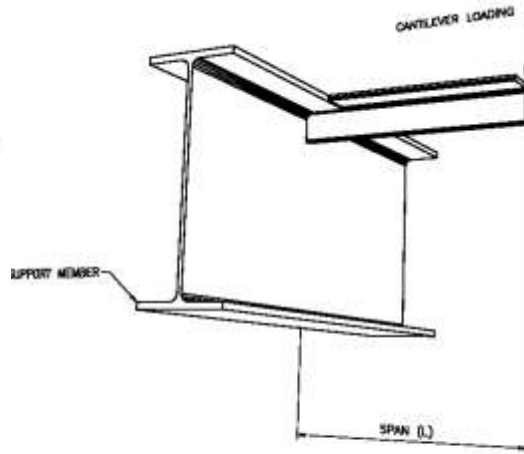

FIGURE 2
CANTILEVER MEMBER – HORIZONTAL
SCALE: 1-1/2" = 1'-0"

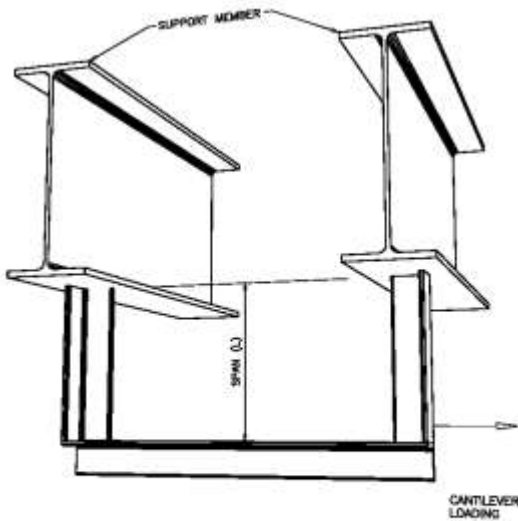

FIGURE 3
CANTILEVER MEMBER – VERTICAL
SCALE: 1-1/2" = 1'-0"

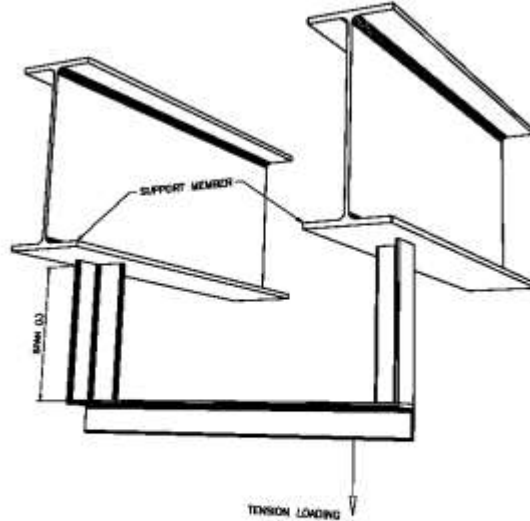
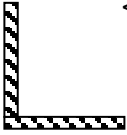

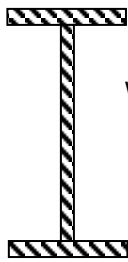

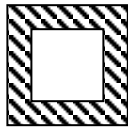

FIGURE 4
TENSION MEMBER – VERTICAL
SCALE: 1-1/2" = 1'-0"

Manual Section 7	Issue Date 12/01/09	Revision Date 06/15/21	Policy Number LLCP-068
	Fall Hazard Management		

Member	Span (L) (feet)	Midspan Loading	Cantilever Load	Tension Load
		Figure 1 Member Acceptable Per Fall Protection Standard	Fig 2 & 3 Member Acceptable Per Fall Protection Standard	Fig 4 Member Acceptable Per Fall Protection Standard
	<3x3	2	No	No
		5	No	No
		10	No	No
<4x4	2	No	No	Yes
	5	No	No	Yes
	10	No	No	Yes
<5x5	2	Yes	No	Yes
	5	No	No	Yes
	10	No	No	Yes
<6x6	2	Yes	No	Yes
	5	No	No	Yes
	10	No	No	Yes
	C4	2	Yes	Yes
		5	No	Yes
		10	No	Yes
C6	2	Yes	No	Yes
	5	Yes	No	Yes
	10	No	No	Yes
C8	2	Yes	Yes	Yes
	5	Yes	No	Yes
	10			
C10	2	Yes	Yes	Yes
	5	Yes	No	Yes

Manual Section 7	Issue Date 12/01/09	Revision Date 06/15/21	Policy Number LLCP-068
	Fall Hazard Management		

		10	Yes	No	Yes
	W4	2	Yes	No	Yes
		5	Yes	No	Yes
		10	No	No	Yes
	W6	2	Yes	No	Yes
		5	Yes	No	Yes
		10	No	No	Yes
	W8	2	Yes	Yes	Yes
		5	Yes	No	Yes
		10	Yes	No	Yes
	W10	2	Yes	Yes	Yes
		5	Yes	No	Yes
		10	Yes	No	Yes
	W12	2	Yes	Yes	Yes
		5	Yes	Yes	Yes
		10	Yes	No	Yes
	TS 2x2	2	No	No	Yes
		5	No	No	Yes
		10	No	No	Yes
	TS 3X3	2	Yes	No	Yes
		5	No	No	Yes
		10	No	No	Yes
	TS 4X4	2	Yes	No	Yes
		5	No	No	Yes
		10	No	No	Yes
	TS 5X5	2	Yes	No	Yes
		5	Yes	No	Yes

Manual Section 7	Issue Date 12/01/09	Revision Date 06/15/21	Policy Number LLCP-068
	Fall Hazard Management		

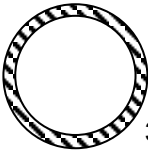
	10	No	No	Yes
TS 6X6	2	Yes	Yes	Yes
	5	Yes	No	Yes
	10	Yes	No	Yes
2"SCHD 40	2	No	No	No
	5	No	No	No
	10	No	No	No
	3"SCHD 40	2	Yes	Yes
		5	No	Yes
		10	No	Yes
4"SCHD 40	2	Yes	No	Yes
	5	No	No	Yes
	10	No	No	Yes
5"SCHD 40	2	Yes	No	Yes
	5	Yes	No	Yes
	10	No	No	Yes
6"SCHD	2	Yes	Yes	Yes
	5	Yes	No	Yes
	10	Yes	No	Yes

Safety Nets

The maximum size of each safety net mesh opening shall not exceed 36 square inches or be longer than 6 inches on any side measured center to center of the mesh ropes or webbing. All mesh crossings shall be secured to prevent enlargement of the mesh opening.

Each safety net (or section of it) shall have a border rope for webbing with a minimum breaking strength of 5,000 pounds.

Connections between safety net panels shall be as strong as integral net components and shall be spaced not more than 6 inches apart.

Safety nets shall be installed as close as practicable under the walking/working surface on which employees are working, but in no case no more than 10 feet below such level.

Manual Section 7	Issue Date 12/01/09	Revision Date 06/15/21	Policy Number LLCP-068
	Fall Hazard Management		

Safety nets shall extend outward at least 8 feet from the outer most projection of the work surface.

Safety nets shall be installed with sufficient clearance under them to prevent contact with the surface or structures below when subject to an impact force equal to the drop test specified below.

Safety nets and their installations shall be capable of absorbing an impact force equal to that produced by the drop test specified below.

Safety nets and safety net installations shall be dropped tested at the job site before use as a fall protection system. The drop test shall consist of a 400-pound bag of sand (30 inches in diameter) dropped into the net from the highest walking/working surface on which the employees are to be protected.

Exception: When Project Management can demonstrate that a drop test is not feasible or practicable, the net and the net installation shall be certified by a qualified person to be in compliance with the provisions of this program.

Safety nets shall be inspected weekly for mildew, wear, damage, deterioration, and defective components shall be removed from service.

Materials, scrap pieces, and tools which have fallen into the safety net shall be removed as soon as possible and at least before the next work shift.

Catch Platforms

A catch platform shall be installed within 6 vertical feet of the work area.

The catch platform's width shall be equal the distance of the fall but shall be a minimum of 45 inches wide and shall be equipped with standard guardrails on all open sides.

Before permitting employees into areas where fall hazards exist the superintendent shall:

- Insure the fall protection plan covers the work being performed
- Ensure that all supervisors and employees are trained and instructed in the items described
- Inspect fall protection devices and systems to ensure compliance with applicable parts of the procedure.

Guarding of Low-Pitched Roof Perimeters

General

During the performance of work on low-pitched roofs with a ground-to-eaves height greater than 6 feet, project management shall ensure that employees engaged in such work are protected from falling from all unprotected sides and edges of the roof as follows:

- By the use of a fall restraint or fall arrest system, as defined in applicable OSHA or state regulations

Manual Section 7	Issue Date 12/01/09	Revision Date 06/15/21	Policy Number LLCP-068
	Fall Hazard Management		

- By the use of a warning line system, erected and maintained as described in this Practice, and supplemented for employees working between the warning line and the roof edge by the use of a safety monitor system as described in Title 29 Code of Federal Regulations Part 1926 Subpart M.
- Mechanical equipment shall be used or stored only in areas where employees are protected by a warning line system, or fall restraint, or fall arrest systems as described in applicable federal or state regulations.
- Mechanical equipment may not be used or stored where the only protection provided is a safety monitor.

Exceptions: The provisions above do not apply at points of access such as stairways, ladders and ramps, or when employees; use on the roof only to inspect, investigate, or estimate roof level conditions. Roof edge materials handling areas and materials storage areas shall be guarded.

- Employees engaged in built-up roofing on low-pitched roofs less than 50 feet wide may elect to use a safety system without warning lines where the use of hot tar poses an additional hazard to workers.

Warning Line Systems

Warning lines shall be erected around all sides of the work area:

- When mechanical equipment is not being used, the warning line shall be erected not less than 6 feet from the edge of the roof.
- When mechanical equipment is not being used, the warning line shall be erected not less than 6 feet from the roof edge which is parallel to the direction of mechanical equipment operation, and not less than 10 feet from the roof edge which is perpendicular to the direction of mechanical equipment operation.
- The warning line shall consist of a rope, wire, or chain and supporting stanchions erected as follows:
- The rope, wire, or chain shall be flagged at not more than 6 feet intervals with high-visibility material.
- The warning line shall be rigged and supported in such a way that its lowest point (including sag) is no less than 34 inches from the roof surface, and its highest point is no more than 39 inches from the roof surface.
- After the warning line is erected, the stanchions shall be capable of resisting, without tipping over, a force of at least 16 pounds applied horizontally against the stanchion, 30 inches above the roof surface, perpendicular to the warning line, and in the direction of the roof edge.
- The rope, wire, or chain shall have minimum tensile strength of 500 pounds, and after being attached to the stanchions, shall be capable of supporting, without breaking, the loads applied to the stanchions.
- The line shall be attached at each stanchion in such a way that pulling on one section of the line between stanchions will not result in slack being taken up in adjacent sections before the stanchion tips over.

Manual Section 7	Issue Date 12/01/09	Revision Date 06/15/21	Policy Number LLCP-068
	Fall Hazard Management		

Paths shall be erected as follows:

- Points of access, material handling areas, and storage areas shall be connected to the work area by a clear access, path formed by two warning lines.
- When the path to a point of access is not in use, a rope, wire, or chain, equal in strength and height to the warning line, shall be placed across the path at the point where the path intersects the warning line erected around the work area.

Roof Edge Material Handling Areas and Material Storage

Employees working in a roof edge material handling or storage area on a low-pitched roof with a ground-to-eave height greater than 6 feet shall be protected from falling along all unprotected roof sides and edges of the area.

When guardrails are used at hoisting areas, a minimum of 4 feet of guardrail shall be erected on each side of the access point through which materials are hoisted. A chain or gate shall be placed across the opening between the guardrail sections when hoisting operations are not taking place. When guardrails are used at bitumen pipe outlets; a minimum of 4 feet of guardrail shall be erected on each side of the pipe.

When safety harness systems are used, they shall not be attached to the hoist. When fall restraint systems are used, they shall be rigged to allow the movement of employees only as far as the roof edge.

Materials shall not be stored within 6 feet of the roof edge unless guardrails are erected at the roof edge.

Leading Edge Control Zone

When performing leading edge work, project management shall ensure that a control zone is established according to the following requirements:

- The control zone shall be a minimum of 6 feet and a maximum of 25 feet back from the leading edge to prevent exposure by employees who are not protected by fall restraint or fall arrest systems.
- The control zone shall be separated from other areas of the low pitched roof or walking/working surface by the erection of a warning line system.
- The warning line system shall consist of wire, rope, or chain supported on stanchions, or a method which provides equivalent protection. Plastic ribbon shall not be used. Each line shall have a minimum breaking strength of 200 pounds.
- Each line shall be flagged with a highly visible material at intervals not to exceed 6 feet.
- The spacing and support of the line shall keep the line at least 39 inches (including sag) and not more than 45 inches above the working/walking surface.
- The control line shall extend the entire length of the unprotected or leading edge and shall be roughly parallel to the leading edge.
- When positive means of fall protection as described in this Practice are not used, a Safety Monitor System, as described in shall be implemented to protect employees working between the forward edge of the warning line and the leading edge.

Manual Section 7	Issue Date 12/01/09	Revision Date 06/15/21	Policy Number LLCP-068
	Fall Hazard Management		

Safety Monitor System

A safety monitor system may be used in conjunction with a warning line system as a method of guarding against falls during work on low-pitched roofs and leading edge work only.

When selected, the employer shall ensure that the Safety Monitor System, shall be addressed in the Fall Protection Work Plan; shall include the name of the Safety Monitor(s) and the extent of their training in both the Safety Monitor and Warning Line Systems, and shall ensure that the following requirements are met. The Safety Monitor System shall not be used when adverse weather conditions create additional hazards. A person acting in the capacity of Safety Monitor(s) shall be trained in the function of both the Safety Monitor and Warning Lines Systems, and shall:

- Be a Competent Person as defined in Title 29, CFR Part 1926,
- Have control authority over the work as it relates to fall protection,
- Be instantly distinguishable from members of the work crew,
- Engage in no other duties while acting as safety monitor,
- Be positioned in relation to the workers under their protection, so as to have a clear, unobstructed view and be able to maintain normal voice communication and
- Not monitor more than eight exposed workers at one time.

Control zone workers shall be distinguished from other members of the crew by wearing a high-visibility vest only while in the control zone.

Hole Covers

All holes in floors, roofs, and walking working surfaces shall be covered with approved covers.

Covers located in roadways and vehicular aisles shall be capable of supporting at least twice the maximum axle load of the largest vehicle expected to cross over the cover.

All other covers shall be capable of supporting at least twice the weight of employees.

All covers shall be secured to prevent accidental displacement.

All covers shall be colored coded or marked "**Hole Cover, Do Not Remove**".

Rescue of Suspended Employees

Rescue Plans shall be provided to assist in prompt rescue for suspended employees. Employees shall be able to rescue themselves or prompt rescue shall be available.

Rescue equipment shall be inspected quarterly. The inspection shall be documented.

Rescue equipment shall be identified in the project Fall Protection Plan. All rescue equipment shall be immediately available.

Guard Rail Systems

Temporary guardrail systems shall be capable of supporting 200 pounds of force directed either downward or toward the fall hazard.

Manual Section 7	Issue Date 12/01/09	Revision Date 06/15/21	Policy Number LLCP-068
	Fall Hazard Management		

Upright supports shall be no more than eight feet apart.

Guardrail systems shall consist of a hand rail about 42 inches above the floor (plus or minus 3 inches) and a mid-rail located midway between the floor and handrail. Toe boards shall be placed around the bottom of the guardrail system.

If wire rope is used for guardrail systems, the wire rope shall not have more than three inches of deflection. The openings between the wire ropes shall not exceed 19 inches.

Employees shall use a fall arrest system when placing/removing guardrail systems or when an employee should need to enter the guarded area that has the possibility of a fall.

Employees shall not tie off to guardrail systems.

Additional Practices Requiring Fall Restraint/Arrest

Employees shall use Fall Restraint or Fall Arrest equipment when conducting the following activities or work on/from the following equipment:

- Ladders
- Suspended Scaffold
- Two-Point Suspension Scaffold
- Boatswain's Chair Scaffold
- Needle-Beam Scaffold
- Ladder Jack Scaffold
- Window Jack Scaffold
- Float or Ship Scaffold
- Pump Jack Scaffold
- Boom-Supported Elevating Work Platforms
- Vehicle-Mounted Elevated and Rotating Work Platform

Guarding Open Decks

Any deck opening larger than 1 foot by 1 foot (1'x1') must be guarded by handrails that meet the following requirements.

- A minimum height of 42 inches to the top of the guardrail.
- A guardrail must be capable of supporting a load of at least 200 pounds applied in any downward or outward direction, at any point on the top rail or corresponding member.
- A guardrail shall have a standard toe board and intermediate rail or fencing from top to bottom.
- The access gate must be kept closed and shall be only opened for personnel to enter or exit the area enclosed by the guardrail.

Manual Section 7	Issue Date 12/01/09	Revision Date 06/15/21	Policy Number LLCP-068
	Fall Hazard Management		

- Openings that are smaller than 1 foot x 1 foot do not have to meet these guidelines, but they do have to properly identified and marked.
- All deck openings, regardless of the height, shall be identified and marked.

Ladders

“Do’s and don’ts” concerning ladder safety:

- All ladders must be equipped with anti-slip safety feet.
- Do not use ladders as scaffolding equipment.
- Do not use metal ladders when working with electrical equipment.
- Only one employee is allowed to be working off a ladder at a time.
- Ladder rungs, cleats and steps shall be parallel, level, and uniformly space when the ladder is in position for use.
- Inspect ladders before each use. If the ladder is not in safe condition, tag it for maintenance and remove it from service.
- Never climb a ladder higher than the designated highest standing level. Always use three (3) points of contact while climbing a ladder.
- Ladders must be placed on stable, level surfaces.
- Never stand on either of the top two rungs or top of a step ladder.
- In the event a fall occurs, never carry anything onto the ladder that could cause injury.
- Always face the ladder when ascending or descending the ladder.
- The ladder side rails must extend at least three feet beyond the upper landing surface.
- When a ladder is not able to be extended, then the ladder shall be secured, at its top, to a rigid support that will not deflect.
- Ladders shall not be loaded beyond the maximum intended loads for which they were built, or beyond the manufacturer’s rated capacity.
- Ladders shall be used only for the purpose for which they were designed.

Training

All employees affected by this procedure and required to work above six feet from the working surface or subject to a fall must be trained in this procedure.

The training must include recognition and elimination of fall hazards and at a minimum the following information:

- How to don/doff equipment
- Maintenance of equipment
- The proper use
- How to properly adjust
- How to inspect prior to use
- Useful life of equipment

Manual Section 7	Issue Date 12/01/09	Revision Date 06/15/21	Policy Number LLCP-068
	Fall Hazard Management		

Re-training shall be provided when:

- Deficiencies are found
- Change in workplace settings
- Equipment changes

Accident Investigation

All accidents and serious incidents involving falls should be investigated, implementing changes to the fall protection plan as necessary.

Record Retention

The Fall Protection Plan shall be maintained in the project HSE office.

Documentation of training in the use of fall protection shall be kept on file in the project HSE office.

Inspection records of fall protection devices shall be kept on file in the project HSE office for the duration of the project.

