

Form Number LLCF-002	Issue Date 05/20/10	Revision Date 06/15/21	Form Number LLCF-002
Aerial Work Platform Inspection Checklist			

Begin the "Walk-Around Inspection" at Item 1, as noted on the diagram on page 3. Continue to the right (counterclockwise viewed from top) checking each item in sequence for the conditions listed.

WARNING

To avoid injury, do not operate a machine until all malfunctions have been corrected, use of a malfunctioning machine is a safety violation. To avoid possible injury, be sure machine power is off during walk-around inspection.

Note: Do not overlook visual inspection of chassis underside. Checking this area often results in discovery of conditions which could cause extensive machine damage.

Name: _____ Date: _____

Item	Inspection These Items:	Condition/ Notes	Correction/Date
1.	Platform Assembly - No loose or missing parts, no visible damage, lock bolts in place. Footswitch in good working order; not modified disabled or blocked.		
2.	Platform Control Console - Switches and levers return to neutral and are properly secured, no loose or missing parts, no visible damage, decals/placards secure and legible, control making legible.		
3.	Slave Cylinder - No visible damage; pivot pins secure hydraulic hoses undamaged, not leaking.		
4.	Boom Sections/Uprights/Lift Cylinders and Master Cylinder - No visible damage; pivot pins secure; hydraulic hoses undamaged, not leaking. Uprights in vertical position.		
5.	Horizontal Limit Switches - Switches operable; no visible damage.		
6.	Drive Motor, Brake and Hub - No visible damage; no evidence of leakage.		
7.	Wheel/ Tire Assembly, Right Rear - Properly secured, no loose or missing lug nuts, no visible damage.		
8.	Hydraulic Filter - Housing secure no visible damage; no evidence of leakage.		
9.	Hood, Right Side - Properly secured; no loose or missing parts.		
10.	Control Valve - No loose or missing parts; evidence of leakage; unsupported wires or hoses; damaged or broken wires.		
11.	Fuel Supply - Filler cap secure, no visible damage to the tank or evidence of leaks.		
12.	Ground Controls - Switches operable, no visible damage. Decals secure and legible.		
13.	Hydraulic Oil Supply - Recommended oil level sight gauge. (Check level with cold oil, systems shut down, machine in stowed position) cap in place and secure.		

Form Number LLCF-002	Issue Date 05/20/10	Revision Date 06/15/21	Form Number LLCF-002
	Aerial Work Platform Inspection Checklist		

Item	Inspection These Items:	Condition/ Notes	Correction/Date
14.	Wheel/Tire Assembly, Right Front - Properly secured, no loose or missing lug nuts, no visible damage.		
15.	Oscillating Axle - No loose or missing hardware; no visible damage.		
16.	Steer Cylinder - Properly secured; no visible damage or signs of leakage; evidence of proper lubrication.		
17.	Tie Rod Ends and Steering Spindles - No loose or missing parts; no visible damage.		
18.	Wheel/Tire Assembly, Left Front - Properly secured, no loose or missing lug nuts, no visible damage.		
19.	Battery - Proper electrolyte levels; cables tight, no visible damage or corrosion.		
20.	Engine Air Filter - No loose or missing parts; no visible damage; element clean.		
21.	Hood, Right Side - Properly secured; no loose or missing parts.		
22.	Engine Oil Supply - Full mark on dipstick; filler cap secure.		
23.	Turntable Bearing - No loose or missing hardware; no visible; evidence of proper lubrication; no evidence of loose bolts or looseness between bearing or structure.		
24.	Swing Motor and Worm Gear - No loose or missing hardware; no visible damage; evidence of proper lubrication.		
25.	Muffler and Exhaust System - Properly secured; no evidence of leakage.		
26.	Auxiliary Power Pump - No loose or missing parts, no evidence of leakage, no damaged wires.		
27.	Hydraulic Pump - No loose or missing parts, no evidence of leakage.		
28.	Wheel/Tire Assembly, Left Rear - Properly secured, no loose or missing lug nuts, no visible damage.		
29.	Rotator Cylinders - No visible damage; cylinder pins secure; hydraulic hoses undamaged and not leaking.		
30.	Platform Gate - Latch, stop, and hinges in working condition and properly secured; no loose or missing parts.		

Aerial Work Platform Inspection Checklist

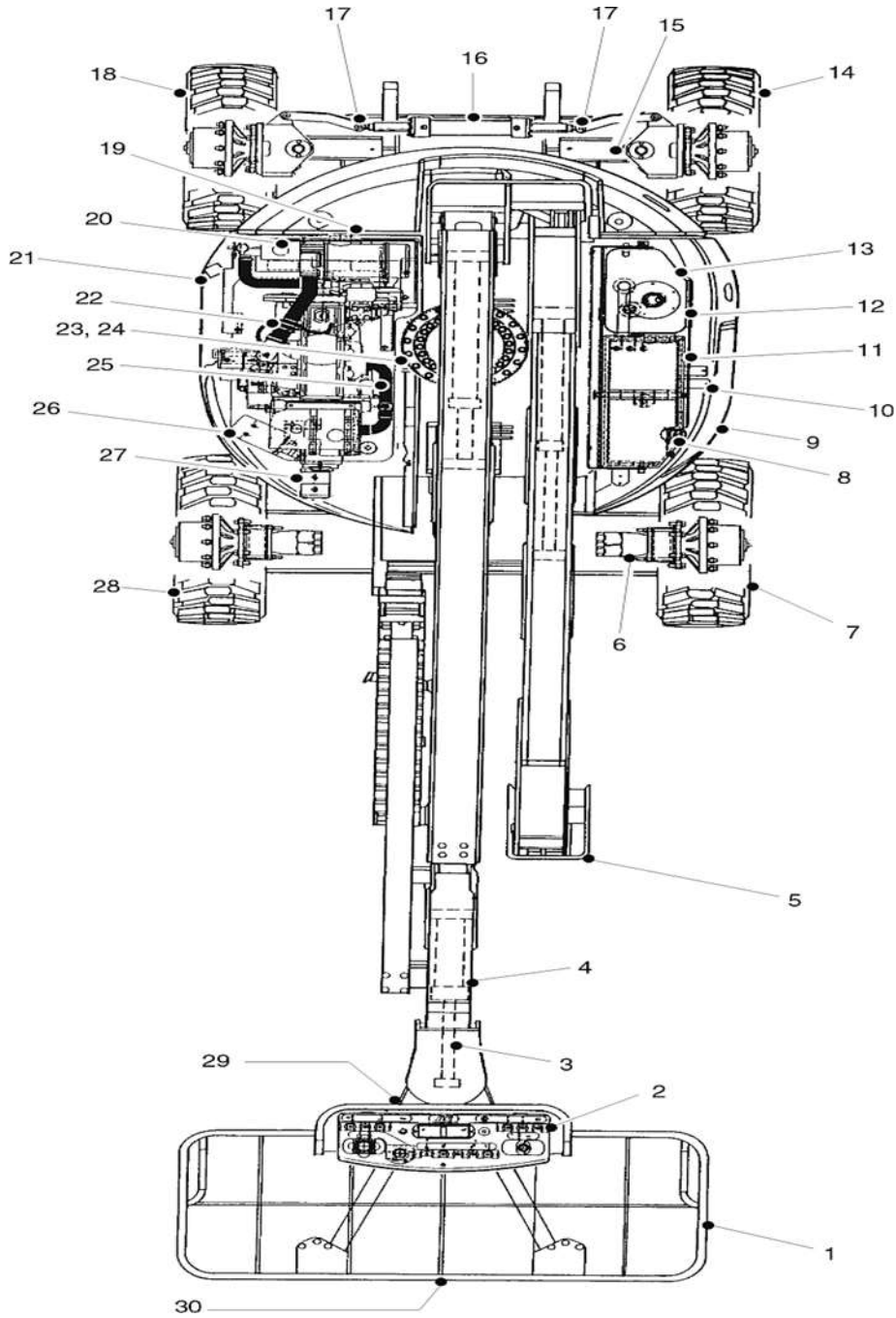

Employee Name:

Employee Title:

Date